

FAITHFULL®
QUALITY TOOLS

FAI AUJACTRO15
FAI AUJACTRO3

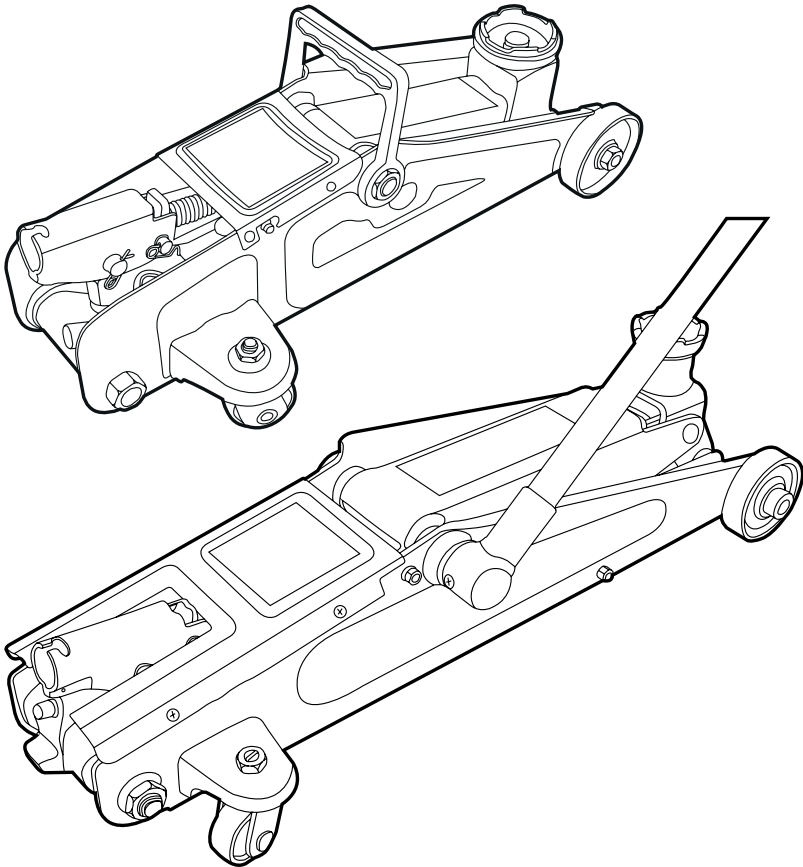

Hydraulic
Trolley Jack
1.5 / 2.5 Tonne



IMPORTANT

It is essential that you read the instructions contained in this manual before using the cable pullers for the first time. Failure to follow these instructions could result in damage to the product, property damage or personal injury. This manual should be stored safely for future reference.

General Safety Instructions

Always access risk factors

- Even when used as prescribed it is not possible to eliminate all residual risk factors. ALWAYS use with caution.

Clean work area

- Accidents occur where work areas are cluttered or dirty. Work areas should be kept clear and clean at all times. Avoid working where an area is slippery due to water, oil, paint or other contaminants on the ground.

Children

- Children should always be kept at a safe distance from any work area. Make any work area or workshop child-proof. Lock tools away where children cannot gain access to them.

Don't use excess force

- Do not force your Jack. It will provide better service if you do not use excessive force when using it.

Use the correct tool

- Do not attempt to use this jack for a purpose that it was not designed for.

Wear correct clothing

- Do not wear loose clothing, neckties or jewellery or other items which may get caught in moving parts. Wear non-slip footwear, cover or tie back long hair, roll long sleeves above the elbow.

Protect your head, eyes and hands

- Wear safety goggles at all times, glasses do not provide adequate eye protection, as lenses are not impact resistant and could shatter.
- Wear suitable gloves.

Keep your balance

- Don't over reach and keep a proper footing at all times to ensure correct balance.

Never stand on your tool

- Standing on your jack could cause injury if the jack tips. Do not store materials above or near the jack so that it is necessary to stand on the jack to reach them.

Check damaged parts

- Before use inspect the jack, if any part of the jack shows signs of wear or damage, **do not use the tool.**

Maintain your tool

- Keep your jack in good working order, keep it clean and oiled. Follow the Instructions for changing accessories and lubrication. Check carefully that it will operate properly and perform its intended operation.

If any parts are damaged do not use this tool.

WARNING: DEATH OR SERIOUS INJURY CAN RESULT WITH IMPROPER USE OF THIS TOOL

Important Safety Rules

Familiarize yourself with these rules and the application, limitations and potential hazards of using the jack.

- **DO NOT** use a trolley jack for any other application other than lifting.
- **DO NOT** exceed the maximum lifting capacity as stated on the product or in the operating manual.
- **DO NOT** allow the vehicle to move during a jacking operation, or use the jack to move a vehicle.
- **DO NOT** operate the jack if any parts are damaged or worn prior to use.
- **DO NOT** top up the hydraulic system with brake fluid. Use hydraulic jack oil only with a rating of SAE 10.
- **DO NOT** use a 'cheater' pipe, lever, or other device to extend the handle length for additional leverage.
- **DO NOT** adjust the safety overload valve. This is correctly set at the factory and no further readjustment is necessary.
- **DO NOT** use a jack to support a lifted load. Appropriate rated axle stands should be correctly positioned and the load lowered as soon as possible, to provide a safe working environment.
- **DO NOT** work under the vehicle until axle stands have been correctly positioned under the vehicle.
- **DO NOT** lift the vehicle if there is a likelihood of spillage of fuel, battery acid, oil or other dangerous fluids.
- **DO NOT** allow an untrained or young person to operate the jack without full supervision.
- **ALWAYS** inspect the jack before use.
- **ALWAYS** use the jack on level solid ground, concrete is preferable. Avoid tarmac surfaces as these are prone to sinking.
- **ALWAYS** ensure the engine is switched off and that there are no passengers in the vehicle.
- **ALWAYS** ensure the vehicle handbrake is engaged and transmission is in gear or "PARK" if the vehicle has an automatic gear box.
- **ALWAYS** chock the wheels of the vehicle to be jacked at the non-lifting end.
- **ALWAYS** place the jack under the lifting point recommended by vehicle manufacturer, check the vehicle handbook if in doubt. Check that the lifting point is sound and centred on the jack saddle prior to lifting.
- **ALWAYS** ensure a minimum distance of 0.5m between the vehicle and any static objects such as walls, doors or other vehicles to allow for the vehicle tilting during lifting.
- **ALWAYS** Ensure the jack wheels are free to move and that there are no obstructions.
- **ALWAYS** store the jack in its retracted position in a safe, dry place.

Specifications



FAI AUJACTRO15

Lifting capacity: 1500kg

Minimum height: 128mm

Maximum height: 300mm

FAI AUJACTRO3

Lifting capacity: 2500kg

Minimum height: 150mm

Maximum height: 430mm

Minimum extended height: 250mm

Maximum extended height: 530mm

Operation Instructions

Fig.2

Open release valve
anti-clockwise

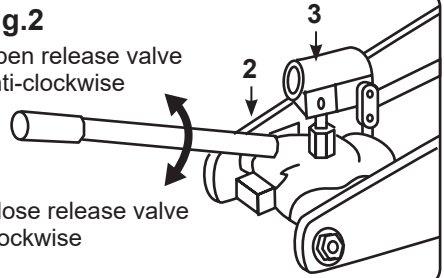

Close release valve
clockwise

- BEFORE USING JACK:** Open the release valve (2) by turning counterclockwise just enough to open valve, do not fully remove the valve from the base (See Fig.2) Insert the handle into the pump sleeve (4) and pump about 6 full strokes to ensure complete distribution of the hydraulic oil.
- TO RAISE:** Close release valve by turning clockwise. Check to see that the saddle (1) is centered on the lifting point and then pump the jack.
- The **FAI AUCJACTRO3** jack features a Quick Lift function, one movement of the lever will lift the saddle to its full working height. This allows the saddle to be quickly brought into contact with the vehicle saving unnecessary pumping. With the release valve closed insert the jack handle in to the Quick Lift Sleeve (4) and push down. Once the saddle has made contact with the vehicle insert the handle into the pump sleeve and operate as normal to raise the vehicle.
- TO LOWER:** Slowly open release valve (2) counterclockwise just enough to open the valve, do not fully remove the valve from the base

Part Identifier

Fig.1

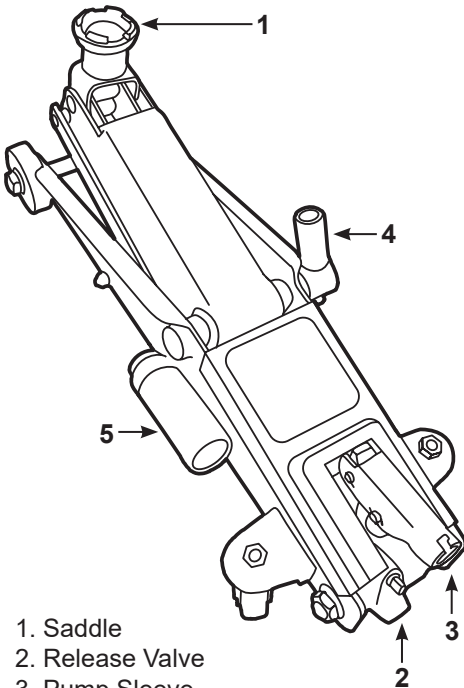

1. Saddle
2. Release Valve
3. Pump Sleeve
4. Quick Lift Sleeve
(FAI AUJACTRO3 ONLY)
5. Saddle Extension
(FAI AUJACTRO3 ONLY)

FAI AUCJACTRO3

Features a 100mm high saddle extension for use on vehicles with a high ground clearance. To extend the saddle height remove the black saddle (1) and insert the saddle extension part (5) into the saddle assembly, then slot the saddle back into the extension. Ensure that the saddle and the extension are fully seated before using the jack.

Problems & Solutions

PROBLEM						SOLUTIONS
Jack will not lift load or full rated capacity	Jack lowers under load	Oil leaking from filler plug	Pump feels spongy	Handle raises or files back under load	Jack will not lift full height	
✓	✓					Release valve may not be tightly closed.
✓			✓		✓	Jack may be low on oil. Remove filler plug and fill reservoir with clean hydraulic jack
		✓				Reservoir may be overfilled. Remove filler plug and drain excess oil.
✓			✓		✓	Jack may be air-bound. Open the release valve and pump the handle several times. Close the release valve and operate. Repeat if necessary.
✓	✓			✓		Valves may not be closed or have foreign matter present. To flush valves. Lower the saddle and close the release. Manually lift the saddle several inches, open the release valve and then force the saddle to lower as rapidly as possible.

General Care Of Your Jack

1. When jack is not in use, lifting arm and handle sleeve should be in full down position. This will protect the precision machined surfaces of the piston rod and pump piston from corrosion.
2. For best results, use an oil with a rating of SAE 10 hydraulic jack oil for refill.
3. Keep your jack clean and lubricate all outside moving parts regularly.