



ELECTRONIC DIGITAL CALIPER

FAI CALDIG

● TECHNICAL SPECIFICATIONS

Measuring range:	0-150mm/0-6in, 0-200mm/0-8in, 0-300mm/0-12in
Resolution:	0.01mm/0.0005in.
Accuracy:	±0.02mm/0.001in (<100mm). ±0.03mm/0.001in (>100-200mm). ±0.04mm/0.0015in (>200-300mm).
Repeatability:	0.01mm/0.0005in.
Max measuring speed:	1.5m/sec, 60in/sec.
Measuring system:	Linear capacitive measuring system.
Display:	LCD display.
Power:	One silver oxide battery 1.55V, type SR44. capacity: 180mAh.
Working temperature:	5 to 40 degree C, 41 to 104 degree F.
Influence of humidity:	Not important under 80% of relative humidity.

● CALIPER FEATURES

- | | |
|----------------------------|-------------------------------|
| 1. Outside measuring faces | 2. Inside measuring faces |
| 3. Depth measuring blade | 4. Step measuring faces |
| 5. Beam | 6. Main scale |
| 7. Battery compartment lid | 8. Output connector |
| 9. Display(LCD) | 10. Slider clamp screw |
| 11. Thumb roller | 12. Power ON/OFF switch |
| 13. ZERO switch | 14. Inch/mm conversion switch |

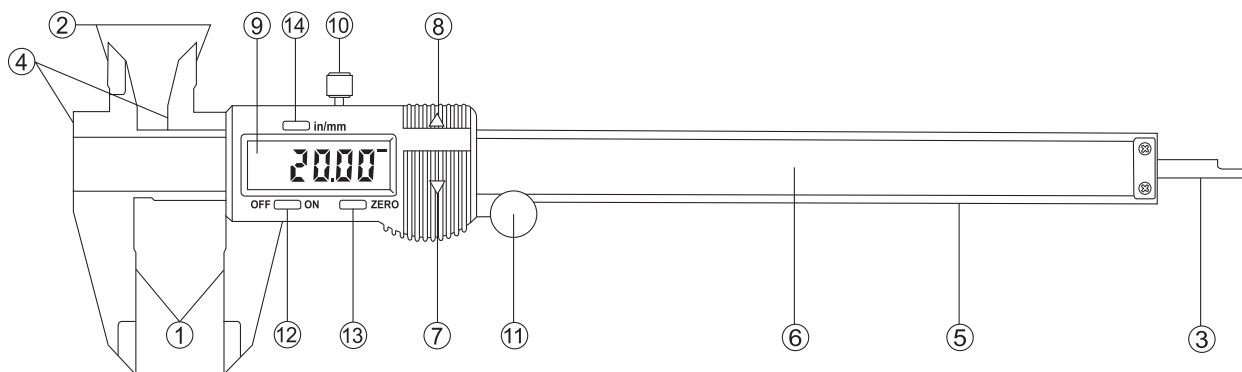

● APPLICATIONS

1. PREPARATIONS FOR USE:

- (1). Loosen the locking screw (No.10) to allow the sliding head to move.
- (2). Wipe clean all the measuring faces and caliper beam with a lint-free cotton cloth.
Never use petrol, acetone and other organic solutions.
- (3). Check to see if all the buttons, switches, and LCD display respond well.

2. BASIC MEASURING METHODS:

- (1). Loosen the locking screw.
- (2). Switch the unit on by pressing the "ON" button. Then select the unit of measurement required by pressing the Inch/Metric button. (Each time the button is pressed, the display will alternate between inch and metric read out).
- (3). Apply normal measuring pressure on the slider to close the external measuring jaws. Then press the "Zero" button to reset the display to zero.

A. Measurements of external dimensions.

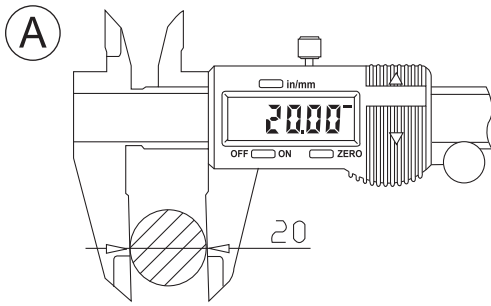

B. Measurements of internal dimensions

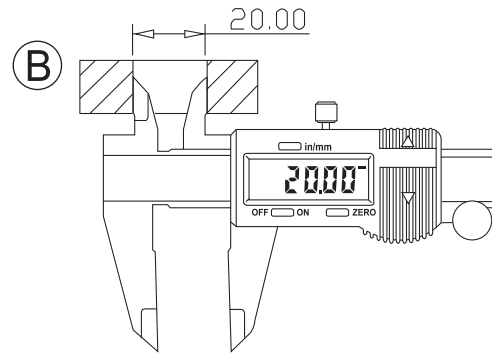

C. Measurements of steps.

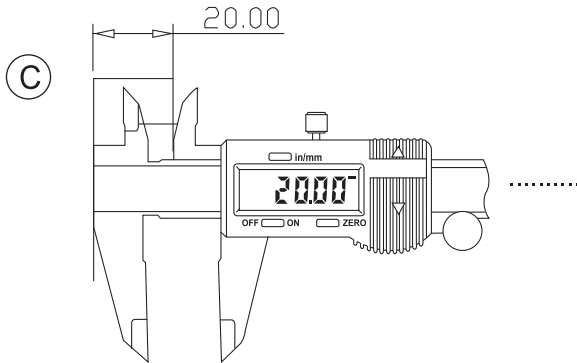

D. Measurements of depth.

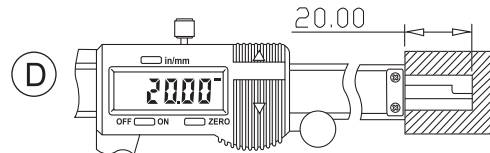

**E. Differential method measurement
(Application of zero setting)**

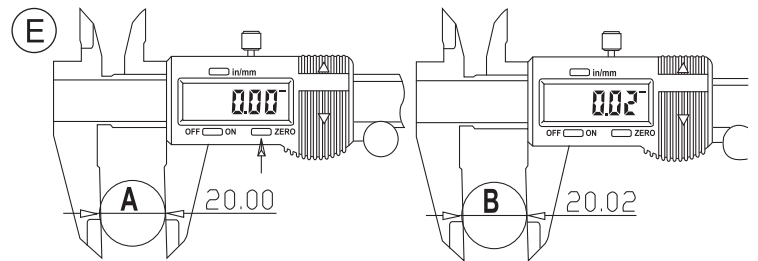

● MAINTENANCE INSTRUCTIONS

1. Keep the caliper clean and dry (Liquid may damage the slider head).
2. Faces should be gently cleaned with a lint-free cotton cloth. Never use petrol, acetone and other organic solutions.
3. In order to save battery power, turn the calipers off if they are to remain unused for an extended period.
4. Never apply any electrical current to any part of the caliper or use active electronic test equipment as this may damage the calipers beyond repair.

● BATTERY REPLACEMENT

Flashing of the digital display indicates that the battery is flat and will require replacing. Remove the battery cover in the direction shown by the arrow and replace the battery (positive side facing out).

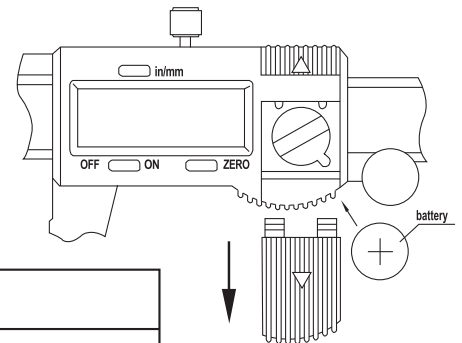

● TROUBLE SHOOTING

Failure	Cause	Measure
Five digits flash simultaneously, about once per second.	Battery voltage lower than 1.45V.	Replace the battery.
Display does not change when the slider is moved.	Problem with the electronic circuit.	Remove the battery and replace it after 30 Sec.
Less accurate than specified but within +0.1mm	Dirt in the sensor.	Remove slider cover and its assembly. Clean with compressed air (5kg/cm).
No display on LCD.	1. Battery in poor contact 2. Battery voltage under 1.4V.	1. Remove battery cover and adjust the battery contact to make a good connection. 2. Replace battery